

GAP CREEK APPROVED FENCING STYLES

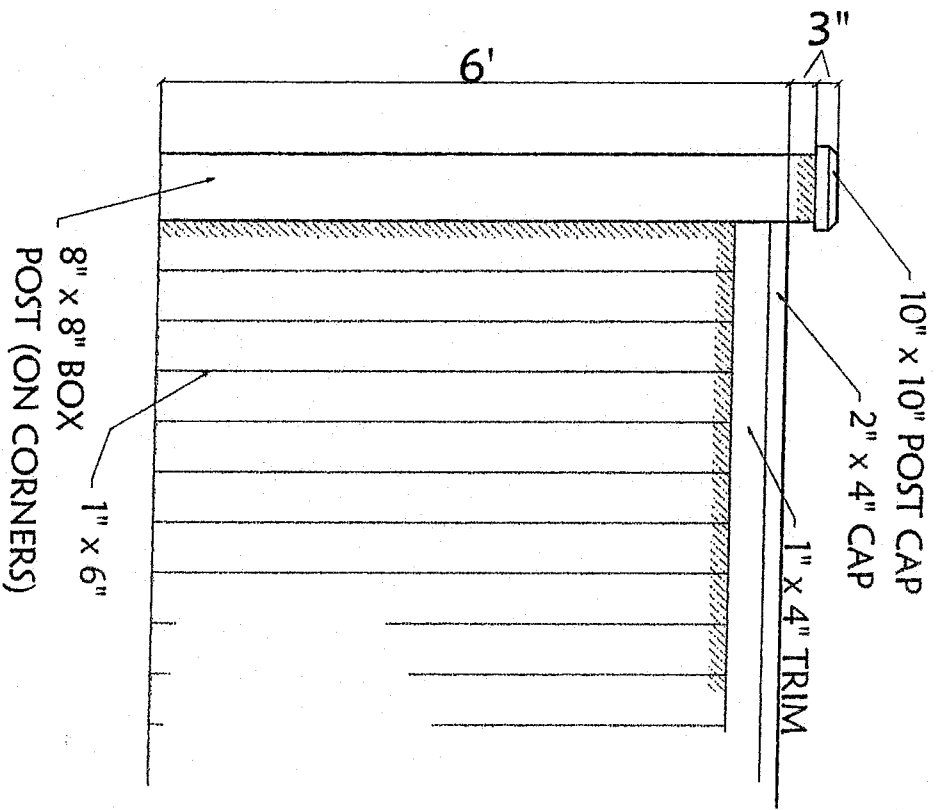

SCALE: 1/2" = 1'-0"

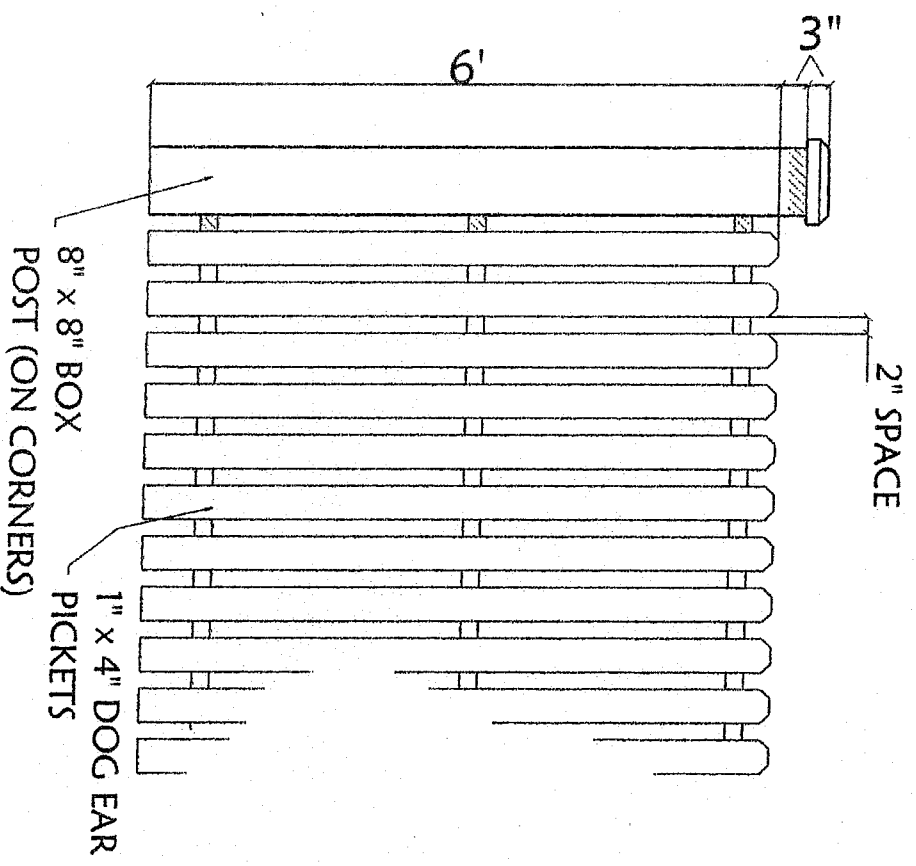

PERIMETER REAR YARD FENCE
OUTWARD FACING ELEVATION

PERIMETER FENCE ADJACENT
TO COMMON AREAS (OPEN SPACE)

* Before any fence is constructed, the design, materials, and location must be approved in writing by Metropolitan Realty & Development, LLC

GAP CREEK MAILBOX SPECIFICATIONS

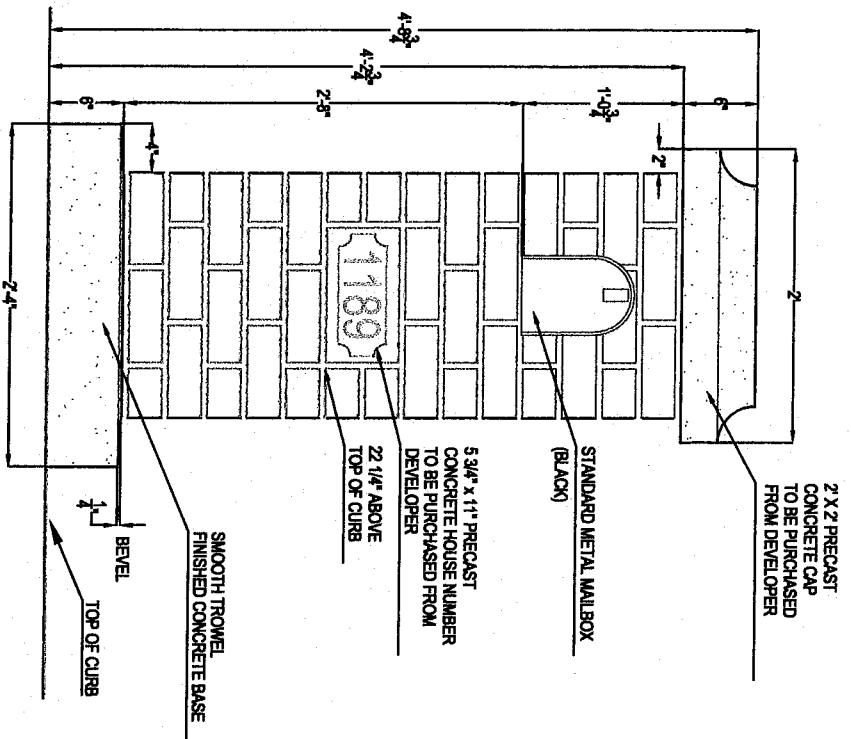

FRONT ELEVATION

BRICK TO MATCH HOUSE OR CULTURED STONE AS SPECIFIED.

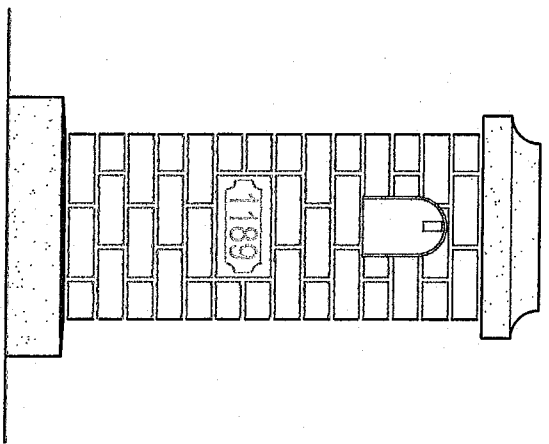

Metropolitan Realty & Development, LLC
7500 Highway 107
Sherwood, Arkansas
501-835-7500

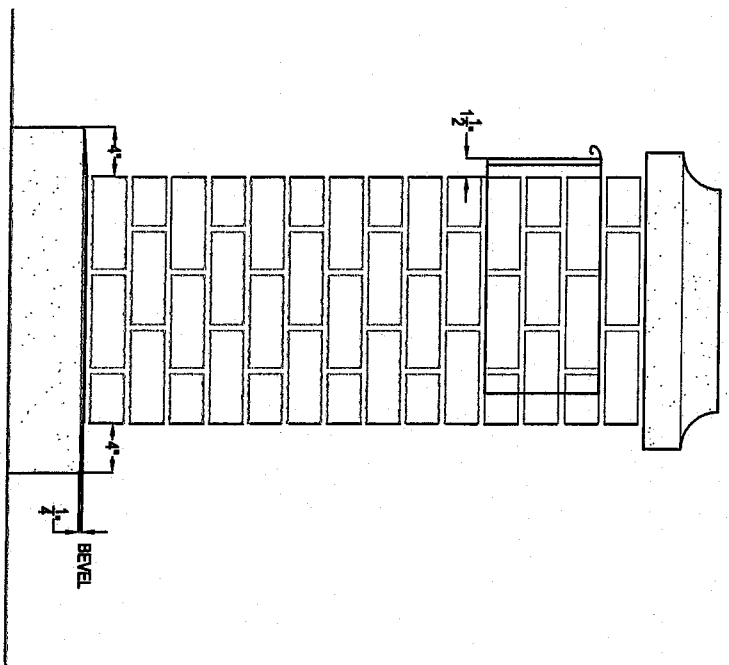

SIDE ELEVATION